



SANDHYAFLEX

ISO 9001:2015 certified company

Cement feeding Rubber Hose / Fly Ash Rubber Hose / Bulker Loading and Unloading Rubber Hose

as per IS: 13071

TECHNICAL DATASHEET

SANDHYAFLEX is an expert in producing sturdy cement hoses that are customized for a range of construction uses. The seamless rubber blend of synthetic and natural rubber compounds used to make the lining of these hoses provides outstanding durability and resistance to abrasion. High-strength natural or synthetic yarns impregnated with rubber piles make up the reinforcement, which adds stability and strength. A weather- and abrasion-resistant rubber compound cover further reinforces the hose and provides protection from inclement weather.

A copper wire strand inserted into the hose also guarantees electrical continuity along its entire length. Sandhya Flex cement hoses are made to endure the harsh conditions of building sites, offering flexibility and user-friendliness along with dependable performance. Customisation possibilities help customers achieve project requirements that are unique to them. Sandhya Flex guarantees that every hose satisfies industry standards and requirements, providing technical assistance and after-sales service to maximise performance. The company is dedicated to quality and client happiness.

Application of Cement Hose is used for spraying cement grout at irrigation projects, buildings, dams, sites, dams, bridges and roads in hilly terrains. More such as:

Construction:

Lining: This is a natural, synthetic, and blended rubber compound tube that is unusually thick, homogeneous, and seamless. It delivers excellent abrasion resistance without air blisters, porosity, or other flaws.

Reinforcement: Rubber piles impregnated woven textiles or braided high-strength natural or synthetic yarns

Cover: This rubber compound is acceptable and has a cloth-marked surface that makes it resistant to weather and abrasions.

Electrical Bonding: To ensure electrical continuity along the entire length of the hose, a stand of copper wire is placed in the reinforcing plies.

Specifications:

Compliant with IS: Our cement hoses, which adhere to IS: 13071-1991 standards, have strong features made to withstand the demanding needs of the construction sector.

Core: The hose's black, abrasion-resistant core, which is made of a sturdy mixture of natural and synthetic rubber, ensures longevity and dependability under harsh conditions.

Reinforcement: Our hoses are reinforced with high-tensile synthetic textile cords, which give them exceptional strength and stability. This allows for the effective placement of sand, plaster, and cement during building projects.

Cover: Made of synthetic rubber in black, our hoses are designed to withstand ozone, weathering, and abrasion, giving them extra endurance and protection in harsh environments.

Application: Our hoses are designed to provide outstanding performance and dependability, making them perfect for precisely placing sand, cement, and plaster in construction applications.







History of Cement Feeding / Fly Ash / Bulker Loading Rubber Hoses:

- **19th Century Origins:** Early industrial hoses were made from leather and fabric, later replaced by natural rubber hoses for better flexibility and durability.
- **Early 1900s Development:** Reinforced rubber hoses with textile layers and steel wire were introduced for handling abrasive industrial materials such as cement, sand, and powders.
- **1940s Industrial Expansion:** Growth of cement plants, power stations, and pneumatic conveying systems increased demand for heavy-duty rubber hoses for dry bulk material transfer.
- **1950s–1960s Fly Ash Usage:** Thermal power plants began using specialized abrasion-resistant hoses for fly ash conveying and unloading operations.
- **1970s Bulker Loading Systems:** Bulk cement trucks (“bulklers”) widely adopted pneumatic loading and unloading systems using flexible cement rubber hoses for faster and dust-free transfer.
- **Modern Era:** Advanced hoses now use NR/SBR synthetic rubber, textile reinforcement, steel wire helix, and anti-static compounds for handling cement, fly ash, lime, clinker, and other abrasive materials efficiently.

Materials :

The Cement Feeding Rubber Hose / Fly Ash Rubber Hose / Bulker Loading Hose shall be manufactured from high-quality synthetic rubber compounds suitable for handling abrasive bulk materials such as cement and fly ash.

The hose shall consist of an abrasion-resistant inner lining, reinforced with textile cords and/or steel wire helix, and a weather-resistant outer cover. The compound shall contain suitable additives to provide strength, flexibility, abrasion resistance, and durability for pneumatic conveying applications.

RAW MATERIALS OF CEMENT FEEDING RUBBER HOSE				
S. No.	Raw Material	Image	Typical Grade / Example	Function / Purpose
1	Natural Rubber (NR)		SMR 20, STR 20	<ul style="list-style-type: none"> Provides elasticity, flexibility Good abrasion resistance High tear strength
2	Styrene Butadiene Rubber (SBR)		SBR 1502, SBR 1712	<ul style="list-style-type: none"> Improves wear and abrasion resistance Enhances aging and heat resistance
3	Carbon Black		N550, N660	<ul style="list-style-type: none"> Reinforces rubber Improves abrasion resistance Increases tensile strength
4	Reinforcement Material		Polyester / Nylon Fabric Steel Wire Helix	<ul style="list-style-type: none"> Provides strength and durability Withstands pressure and vacuum Maintains hose shape
5	Plasticizers / Process Oil		Paraffin Oil Aromatic Oil	<ul style="list-style-type: none"> Improves flexibility Aids in processing Enhances workability
6	Additives		Zinc Oxide, Stearic Acid Antioxidant, Anti-ozonant Anti-static Agent	<ul style="list-style-type: none"> Activates vulcanization process Protects against aging and ozone Provides anti-static property
7	Curing System		Sulfur Accelerators (CBS, TMTD) Activators	<ul style="list-style-type: none"> Ensures proper vulcanization Improves crosslinking Enhances durability and strength

RAW MATERIALS → MIXING → CALENDERING / EXTRUSION → HOSE BUILDING → VULCANIZATION → FINISHED HOSE

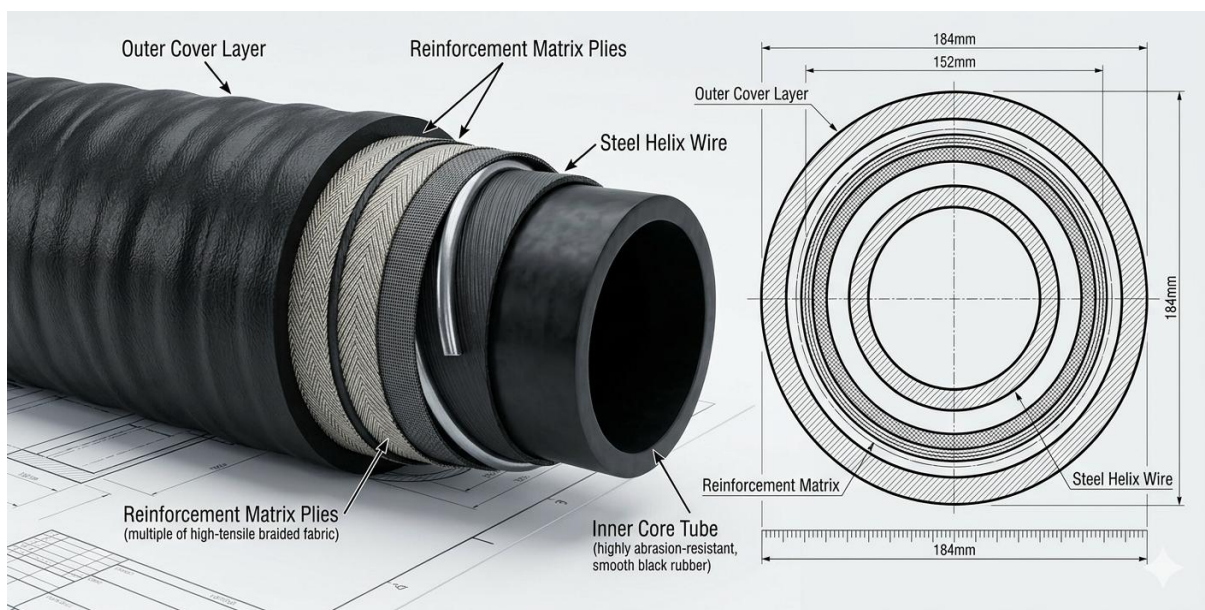

ILLUSTRATIONS OF THE CEMENT FEEDING RUBBER HOSE

COLOUR AND ITS APPLICATION:

Hose Type / Color	Typical Application
Black Rubber Hose	Cement feeding and bulk powder transfer
Grey Rubber Hose	Fly ash conveying and industrial pneumatic systems
Blue Marked Hose	Compressed air and dry bulk material handling
Green Marked Hose	Slurry, ash, and industrial waste handling
Yellow Stripe Hose	High-visibility industrial transfer applications
Red Stripe Hose	Heavy-duty pressure conveying systems
Steel Wire Reinforced Hose	Bulker loading and unloading operations
Anti-Static Rubber Hose	Pneumatic conveying of cement and fly ash

For industries and contractors seeking reliable bulk material conveying solutions, SANDHYAFLEX is the trusted partner for high-performance Cement Feeding Rubber Hoses, Fly Ash Hoses, and Bulker Loading & Unloading Hoses. With a strong commitment to quality, durability, and performance, SANDHYAFLEX delivers dependable hose solutions for cement plants, construction projects, and industrial pneumatic conveying applications.

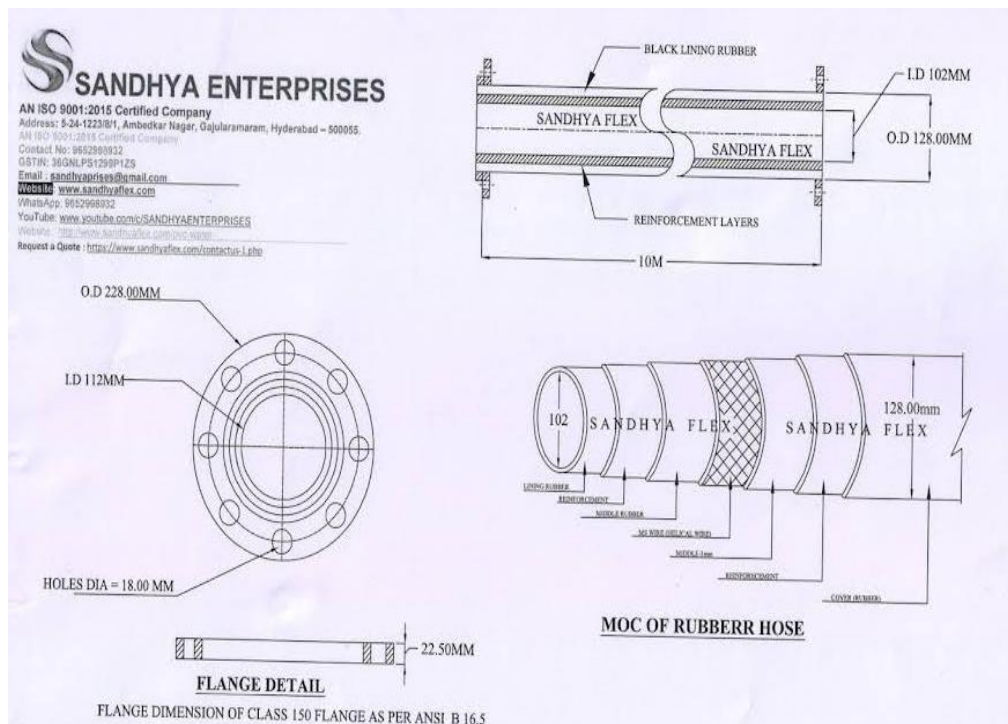

FIG. 1 TYPICAL CROSS-SECTION OF CEMENT FEEDING RUBBER HOSE

INFORMATION REGARDING HOLES AND FLANGE

TABLE D,E & ASA150 COMPARISION

TABLE	SIZE	OD	PCD	NO OF HOLES	HOLES DIA
-------	------	----	-----	-------------	-----------

3" (75MM ID)

ASA 150,ANSI16.5		191	152	4	19
TABLE D		184	146	4	16
TABLE E		184	146	4	16

4" (100 MM ID)

ASA 150,ANSI16.5		229	191	8	19
TABLE D		216	178	4	16
TABLE E		216	178	8	16

5" (125MM ID)

ASA 150,ANSI16.5		254	216	8	22
TABLE D		254	210	8	16
TABLE E		254	210	8	16

6" (150MM ID)

ASA 150,ANSI16.5		279	241	8	22
TABLE D		279	235	8	16
TABLE E		279	235	8	19

Flange Dimension as per ASA 160# ANSI 16.5ASA 160# ANSI 16.5

Sr No	Size	OD of Flange in mm	PCD mm	Nos of Hose	Holes Dia in mm
1	3" (75mm)	190.5	152.4	4	19
2	4" (100mm)	229	190.5	8	19
3	5" (125mm)	254	215.9	8	22.2
4	6"(150mm)	279.4	241.3	8	22.2

Flange Dimension as per Table D

Sr No	Size	OD of Flange in mm	PCD mm	Nos of Hose	Holes Dia in mm
1	3" (75mm)	184	146	4	16
2	4" (100mm)	216	178	8	16
3	5" (125mm)	254	210	8	16
4	6"(150mm)	279	235	8	19

Flange Dimension as per Table E

Sr No	Size	OD of Flange in mm	PCD mm	Nos of Hose	Holes Dia in mm
1	3" (75mm)	184	146	4	16
2	4" (100mm)	216	178	8	16
3	5" (125mm)	254	210	8	16
4	6" (150mm)	279	235	8	19

PHYSICAL INFORMATION:

S No	Size ID of Rubber Hose	Rubber Hose Weight/mtr approx	Flange with Nipple Weight 01 Set	Flange OD as per ASA 150#	Length 6Mtr	Width Flagge OD	Height Flange OD	CBM	Weight/6mtr Hose in Kg
1	3" (75mm)	4kg	12 kg	190.5mm	6	0.191	0.191	0.219	36kg
2	4" (100mm)	5kg	13kg	229mm	6	0.229	0.229	0.315	43kg
3	5" (125mm)	7kg	14kg	254mm	6	0.254	0.254	0.387	56kg
4	6" (150mm)	9kg	19 kg	279.4mm	6	0.280	0.280	0.471	73kg

Working Pressure 10bar

S No	Size Inches	ID (mm)	Weight of Rubber Hose per Mtr	Weight of Flange
1	3	76	4Kg	12kg
2	4	102	5kg	14kg
3	5	127	7Kg	15 kg
4	6	152.4	9kg	19kg

Transportation error shall not be considered.

Cement feeding rubber hoses are fitted with strong metal flanges at both ends for secure connection to pipelines and pumping systems. The flanges contain accurately drilled bolt holes for tight and leak-proof fastening. Depending on hose size and pressure rating, the flange may have 4 or 8 holes with standard hole diameters. Proper flange and hole design ensures safe cement transfer, prevents leakage, reduces vibration, and improves durability in heavy-duty industrial applications.

Cement feeding Rubber Hose / Fly Ash Rubber Hose / Bulker Loading and Unloading Rubber Hose

as per IS: 13071

S.No.	Description	HSN Code	Drawing
1	<p>Size: 3"(75mm) ID x 5Mtr)LG) with Both End MS Flange as per ASA 150#, Drilled ANSI 16.5, Working Pressure 10Bar</p> <p>Flange Dimenision: OD-191mm, RFD 127mm, Holes Dia 19mm No of Hoels 4, PCD 152mm ,weight 37kg/Nos Approx, Make: "SANDHYAFLEX"</p>	4009	
2	<p>Size: 4"(100mm) ID x 5Mtr)LG) with Both End MS Flange as per ASA 150#, Drilled ANSI 16.5, Working Pressure 10Bar</p> <p>Flange Dimenision: OD-229mm, RFD 157mm, Holes Dia 19mm No of Hoels 8, PCD 191mm, weight 40kg/Nos Approx. Make: "SANDHYAFLEX"</p>	4009	
3	<p>Size: 5"(125mm) ID x 5Mtr)LG) with Both End MS Flange as per ASA 150#, Drilled ANSI 16.5, Working Pressure 10Bar</p> <p>Flange Dimenision: OD-254mm, RFD 186mm, Holes Dia 22mm No of Hoels 8, PCD 216mm, Weight 50kg/Nos Approx. Make: "SANDHYAFLEX"</p>	4009	
4	<p>Size: 6"(150mm) ID x 5Mtr)LG) with Both End MS Flange as per ASA 150#, Drilled ANSI 16.5, Working Pressure 10Bar</p> <p>Flange Dimenision: OD-279mm, RFD 216mm, Holes Dia 22mm No of Hoels 8, PCD 241.6mm, weight 65kg/nos, Make: "SANDHYAFLEX"</p>	4009	

PHYSICAL AND CHEMICAL PROPERTIES

- Operating Bar: 10 Bar (10 kg/cm³)
- Proof pressure equal to 1.5 W.P.
- Peak Pressure: Three times W.P
- Two or three galvanised wire helices embedded in layers of rubber compounds serve as reinforcement.
- End Connection: Type of Built-in Flange
- Maximum Length: 15 Metres to 5 Inches
- Use: Sand and gravel, mud slurry, concrete slurry, mining particles, etc. suction and discharge.
- Bore: Smooth Bore Curvature Radius: 10 times the inner Hose Vacuum Diameter: Minimum 700 mmHg (0.9 Bar)
- Material for lining: NR/SBR unable to be penetrated by corrosive and abrasive products 50 to 60 Shore A hardness.
- Carcass: Steel Helix Coated Embedded in Synthetic Textile Plies Content: Adaptability to Adverse and Severe Weather
- Temperature range: -1°C to 100°C

The above tests are carried out on specially moulded test pieces as per IS:13071 Specification specification and found satisfactory.

APPLICATIONS BY COUNTRIES :

India

- Widely used in cement plants and ready-mix concrete (RMC) industries.
- Essential for pneumatic conveying of dry cement, fly ash, and abrasive powders.
- Common in infrastructure, highway, and metro rail construction projects.

China

- Massive demand due to rapid industrialization and mega infrastructure projects.
- Cement feeding rubber hoses are extensively used in automated bulk material transfer systems.
- Important in tunnel construction and high-capacity cement conveying networks.

United States

- Used in cement tanker unloading and industrial powder handling systems.
- Common in highway, bridge, and commercial construction projects.
- Widely applied in mining and heavy-duty pneumatic conveying operations.

Germany

- Strong demand in automated cement plants and precast concrete manufacturing units.
- Used in high-pressure cement conveying and industrial powder transfer applications.
- Preferred for durability and abrasion resistance in industrial environments.

United Arab Emirates

- Extensively used in high-rise building and smart city construction projects.
- Important for dry cement transfer in desert construction conditions.
- Common in marine and port infrastructure developments.

Saudi Arabia

- Used in oil & gas infrastructure and mega industrial projects.
- Essential for bulk cement transfer in large-scale construction activities.
- Applied in desert pipeline and material conveying systems.

Australia

- Widely used in mining, quarrying, and bulk cement handling operations.
- Common in cement tanker discharge and industrial material transfer systems.
- Important for infrastructure and remote construction projects.

South Africa

- Used in mining industries and cement conveying applications.
- Important for dam, road, and infrastructure development projects.
- Preferred in rugged environments due to flexibility and durability.

Qatar

- High demand from stadium, airport, and urban infrastructure projects.
- Used in concrete batching plants and pneumatic cement transfer systems.
- Essential for fast-track construction activities.

Singapore

- Used in advanced urban construction and underground infrastructure projects.
- Common in high-pressure cement conveying systems.
- Applied in marine and tunnel engineering works.

Brazil

- Widely used in cement manufacturing and bulk powder handling industries.
- Important for infrastructure and industrial construction projects.
- Applied in mining-related cement transfer operations.

Africa

- Used in irrigation canal lining and infrastructure-related construction works.
- Important in mining and cement handling industries across developing regions.
- Preferred in remote construction areas because of easy installation and long service life.

Advantageous Properties: SANDHYAFLEX Cement Feeding Rubber Hoses boast:

- High abrasion resistance for handling dry cement and abrasive materials efficiently.
- Excellent flexibility for easy installation and smooth operation in conveying systems.
- High tensile strength for durability under heavy-duty industrial applications.
- Weather and ozone resistance for reliable outdoor performance.
- Superior pressure handling capability for pneumatic cement conveying systems.
- Corrosion and chemical resistance for long service life in harsh environments.
- Leak-proof construction ensuring safe and efficient material transfer.
- Robust inner lining designed to minimize wear during continuous cement flow.

Get in touch:

Address : 5-24-1223/5/1, Ambedkar Nagar, Gajularamaram, Quatubulapur, R. R. Dist, Hyderabad, Telangana - 500055, India

PhoneNo : [\(+91\) 9652998932](tel:+919652998932)

[\(+91\) 6304766851](tel:+916304766851)

[\(+91\) 8074580219](tel:+918074580219)

[\(+91\) 9392275616](tel:+919392275616)

[\(+91\) 8919488523](tel:+918919488523)

[\(+91\) 9550921831](tel:+919550921831)

[\(+91\) 8688537041](tel:+918688537041)

Email : info@sandhyaflex.com